

Open Access Article

## Increasing of Drainage Channel Capacity by Using Under-drain Box Storage Model

Ari Murdhianti<sup>1\*</sup>, Lily Montarcih Limantara<sup>2</sup>, Pitojo Tri Juwono<sup>2</sup>, Dian Sisinggih<sup>2</sup>, Dwi Priyantoro<sup>2</sup>

<sup>1</sup> Doctoral Program in Water Resources Engineering, Faculty of Engineering, Universitas Brawijaya, Malang, Indonesia

<sup>2</sup> Department of Water Resources, Faculty of Engineering, University of Brawijaya, Malang, Indonesia

**Abstract:** The development activity will have an impact on the decrease of water absorption space. If there is happened rainfall, the volume of run-off increases; thus, the right drainage system is needed to fulfill the inundation problem due to the rainfall. The drainage system in the area of Brawijaya University is still using the conventional system, so if there is happened a rainfall, the inundation problem will appear. This research aims to develop the existing drainage system by using the echo-drainage that is Under-drain Box Storage Model. The under-drain box storage is a drainage system with the bottom holes that are serial set along the channel to fill the long storage under the drainage channel directly related to soil. The application of under-drain box storage is through the hydraulic physical model test in the Laboratory of River Engineering, University Brawijaya. The construction of under-drain box storage consists of a rainfall drainage channel, vertical drain hole, and box storage. Based on the research, it is produced the bottom-rack design as follows: the channel bed slope ( $S_o$ )  $\leq 0.001$ , so the Fr number is determined from 0.3 until 0.7, if the channel bed-slope ( $S_o$ )  $> 0.001$ , so the Fr number  $> 0.7$ . By applying the Under-drain Box Storage in the existing drainage channel in the area of Brawijaya University with a two-year return period, the result shows that the construction can reduce 73.73% of inundation; with five-year return period it can reduce 61.07% of inundation, and with ten-year return period it can reduce 58.07% of inundation.

**Keywords:** under-drain box storage, run-off reduction, drainage channel capacity.

## 利用暗箱蓄水模型增加排水渠道容量

**摘要：**開發活動將對吸水空間的減少產生影響。如果發生降雨，則徑流量增加；因此，需要正確的排水系統來解決降雨造成的淹沒問題。布拉維賈亞大學地區的排水系統仍然使用常規系統，所以如果發生降雨，就會出現淹沒問題。本研究旨在利用回波排水系統開發現有排水系統，即地下排水箱蓄水模型。地下排水箱庫是一種排水系統，其底部孔沿通道串聯設置，以填充與土壤直接相關的排水通道下方的長庫。暗渠蓄水箱的應用是通過布拉維賈亞大學河流工程實驗室的水力物理模型試驗。地下排水箱式蓄水池的建設由雨水排水通道、垂直排水孔、箱式蓄水池組成。根據研究，製作底架設計如下：槽床坡度 $\leq 0.001$ ，故確定 Fr 數為 0.3~0.7，若槽床坡度 $> 0.001$ ，則 Fr 數  $> 0.7$ 。通過在布拉維賈亞大學地區現有排水渠道中應用暗渠蓄水箱，兩年重現期，結果表明，該建設可減少 73.73% 的淹沒；五年重現期可減少 61.07% 的淹沒，十年重現期可減少 58.07% 的淹沒。

**关键词：**下排水箱存儲，減少徑流，排水渠道容量。

## 1. Introduction

Land cover change and land use can reflect the pattern of human land use in a region and play an

important role in water conservation and soil space. The surface coverage determines the water flow, earth surface's radiation balance, surface water permeability,

Received: June 13, 2021 / Revised: August 19, 2021 / Accepted: September 21, 2021 / Published: October 30, 2021

About the authors: Ari Murdhianti, Doctoral Program in Water Resources Engineering, Faculty of Engineering, Universitas Brawijaya, Malang, Indonesia; Lily Montarcih Limantara, Pitojo Tri Juwono, Dian Sisinggih, Dwi Priyantoro, Department of Water Resources, Faculty of Engineering, University of Brawijaya, Malang, Indonesia

Corresponding author Ari Murdhianti, [ari.murdhianti391@gmail.com](mailto:ari.murdhianti391@gmail.com)

and material handling. Its spatial distribution and change areas are the important key parameters and basic data of global earth system model research, change research, geographic, sustainable development planning, and others [1, 2].

Most distributed flood models are simple representations of reality, as indicated by the reliance on the coefficients as parameters and quasi-empirical roughness formulations [3-5]. The geometric representation of the flood plain areas and channel also tends to be simplified, based on the elevation of cross-sections along the interested reach. Thus, it should also be expected that the predictions of flood inundation should be uncertain too. In the past, in the magnitude of an event for a given return period, this uncertainty has been considered a function of the uncertainty [6] primarily. At first, the 100 years (return period) event is defined to predict the inundated areas.

The development growth mainly in the urban area that increases will automatically affect the area's demand. This area functions as the retention, the volume of absorption decreases, and then flooding impact happens [7]. The phenomenon of global warming also causes flooding [8] due to the season moving between dry and rainy seasons. In the rainy season, the run-off is automatically increasing, and the impact is flooding. The factor of land-use change and extreme global climate change is needed to be

supported by the concept of a drainage system that can solve the flooding problem. The new concept that is more developed is echo-drainage that is oriented toward water resources conservation.

The Under-drain Box Storage is a conservation drainage concept based on the development of the existing drainage system like absorption well, hole precast rainfall channel, and swale drainage. The technical concept of under-drain box storage is the inundation of rainfall is flowed through the opened channel where there are holes in the bottom that is serial set along the channel which is functioned for filling the long storage; the bed part space of long storage is directly related with soil [9].

## 2. Materials and Method

The research location is on the campus of Brawijaya University, Malang, Indonesia. Geographically, Malang city is located in the east longest of 112.060 – 112.070 and south longest of 7.060 – 8.020. The area of Brawijaya University is 51 hectares. However, the boundary of the campus region of Brawijaya University is as follows: northern is Jl. MT. Haryono; eastern is Jl. Mayjen Panjaitan; western is Jl. Sumbarsari and southern is Jl. Veteran. Map of the Brawijaya University campus region is presented in Fig. 1.



Fig. 1 Map of Brawijaya University campus region, Malang, Indonesia (Google Earth)

The steps of this research are as follow:

### 1. Initial survey

The site review in the beginning step intends to give a general illustration of the nowadays existing condition in the study region. It is carried out in the beginning coordination with the related parties of this study.

### 2. The collecting of technical data

The data collecting in detail was carried out mainly related to the data needed to support the

implementation of this research. Data needed are the rainfall data as the recording result in the rainfall station of Hydrology Laboratory-Water Resources Department-University of Brawijaya-Malang-Indonesia, data of watershed parameter, and discharge data of AWLR Gadang.

## 3. Methodology

The methodology consists of

- a. To recap the maximum daily rainfall from 2007-2019 as the base in analyzing the design flood.
- b. To carry out the consistency test with the method of Rescaled Adjusted Partial Sums (RAPS).
- c. To carry out the data outlier test for knowing the data far enough deviates or not from the group trend.
- d. To carry out the trend absence by using the method of Spearman Rank Correlation.
- e. To carry out the stationer test by using the F test and T-test.
- f. To carry out the persistence test by using the method of Spearman Rank Correlation.
- g. To analyze the design rainfall by using the method of Log Pearson III and Gumbel.
- h. To carry out the testing of the goodness of fit by using the Smirnov-Kolmogorof test and Chi-square test.
- i. To analyze the hourly rainfall intensity by using the method of Mononobe.
- j. To analyze the area of land use in the Brawijaya University.
- k. To analyze the Td and Tc in every channel.
- l. To determine the run-off coefficient for every land use (yard, road, and rooftop).
- m. To analyze the design flood by using a rational method for every land use in the Brawijaya University. The Rational formula is as follow:  

$$Q = 0.278 \times C \times I \times A$$

$$(1)$$
- n. To analyze the total run-off discharge of the whole land use, this is entered into the main drainage channel by the end.

- o. To analyze the backwater due to the channel condition in the main drain.
- p. To analyze the channel capacity of existing drainage in the Brawijaya University.
- q. To evaluate the drainage channel in the Brawijaya University to the total run-off discharge due to the backwater in the main drain.
- r. To design Under-drain Box Storage and the dimension of bottom-rack.
- s. To analyze the discharge that absorbs into soil.
- t. To analyze the water volume after and before the application of Under-drain Box Storage.

## 4. Results and Discussion

### 4.1. Analysis of Hydrology

The consistency test is needed to evaluate the validity of field data that is not affected by the error when delivery or measuring; the data have to illustrate the hydrology phenomenon as the real condition in filed [12]. Then, the data outlier test is carried out to know the data that is far enough deviated from the data group trend. The result shows that the upper limit value ( $X_H$ ) is 201.01, and the lower ( $X_L$ ) is 24.52. Therefore, the recording result for 2008 with the value of 220 m has to be eliminated. The result of the data outlier is evaluated by the consistency and trend absence test. Then, it is carried out the frequency analysis by using the methods of Log Pearson-III and Gumbel. After that, it is carried out the testing of the goodness of fit by using the Kolmogorof-Smirnov and Chi-Square Test. The result can be seen in Tables 1 and 2.

Table 1 Recapitulation of Chi-square test (Own study, 2020)

Frequency analysis	Probability	Chi-critic	Chi-Square Test	Note
Gumbel	1%	6.634	3.833	Accepted
	5%	3.841	3.833	
Log Pearson	1%	6.634	3.833	Accepted
	5%	3.841	3.833	

Table 2 Recapitulation of Kolmogorof-Smirnov test (Own study, 2020)

Frequency analysis	Probability	$\Delta$ critic	Kolmogorof-Smirnov Test	Note
Gumbel	1%	0.375	0.061	Accepted
	5%	0.450		
Log Pearson	1%	0.375	0.163	Accepted
	5%	0.450		

Based on the result in Tables 1 and 2, the method of Log Pearson III has less deviation than the Gumbel method, so the design rainfall used in this research is the result of the Log Pearson-III method presented in Table 3.

Table 3 Recapitulation of design rainfall (Own study, 2020)

Tr	Pr (%)	K	K . SD	X design (mm)
2	50.00	-0.07	-0.01	99.52
5	20.00	0.82	0.08	122.84
10	10.00	1.32	0.14	138.39

Based on the design rainfall, the hourly rainfall distribution is analyzed using the Mononobe method, and the result supports determining the rainfall intensity. The intensity of rainfall is related to duration and frequency, which can be expressed by the Intensity-Duration Frequency (IDF) curve. The IDF curve can analyze the design flood by using the Rational method [10]. Fig. 3 presents the rainfall intensity curve with various return periods.

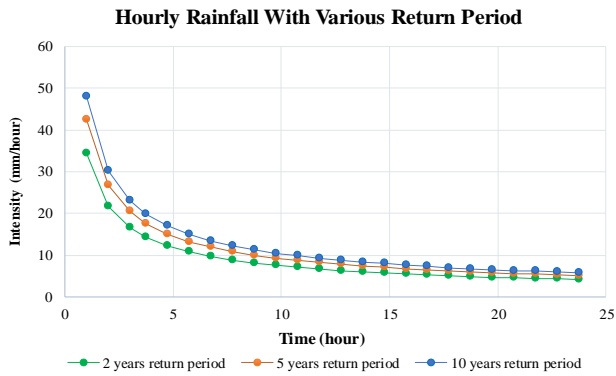

Fig. 3 Rainfall intensity curve with various return periods (Own study, 2020)

#### 4.2. Analysis of Total Run-Off Discharge

The run-off discharge is analyzed by using the Rational Modification method based on the existing land use. The land use in Brawijaya University is classified into three such as yard, road, and roof. The value of the run-off coefficient is obtained from the run-off coefficient for the Rational method [11]. The result is presented in Table 4.

Table 4 Total run-off discharge in every drainage channel with 5 years return period (Own study, 2020)

Zone	Channel	Discharge of rooftop	Discharge of yard	Discharge of road	Total discharge
		(m <sup>3</sup> /s)	(m <sup>3</sup> /s)	(m <sup>3</sup> /s)	(m <sup>3</sup> /s)
1	C – 6.2 R	0.035	0.087	0.009	0.256
	C6.1	0.035	0.049	0.011	0.095
2	C7.1-C8.2 (2b)	0.072	0.101	0.004	0.213
	C7.1-C8.2 (3b)	0.208	0.112	0.007	0.289
	C7.2 (3a)	0.250	0.093	0.000	0.727
	C3.7R/HL	0.026	0.006	0.018	0.051
	C8.4/HL	0.029	0.007	0.025	0.061
	C8.1R (1B)	0.137	0.155	0.004	0.295
	C8.1R (2C)	0.032	0.018	0.008	0.353
	C8.1R (7A)	0.052	0.050	0.019	0.477
3	C7.1-C8.2 (6a)	0.042	0.014	0.018	0.219
	C8.3	0.088	0.064	0.037	0.333
	C8.4/HR (3A)	0.032	0.044	0.003	0.078
	C8.4/HR (3B)	0.090	0.121	0.003	0.691
	C8.4/HR (8A)	0.050	0.046	0.012	0.804
	C8.4/HR (9B)	0.115	0.063	0.013	1.329
	C4.1	0.274	0.276	0.050	0.851
	New line	0.075	0.127	0.029	0.231
	C3.1	0.048	0.077	0.018	0.143
	C.3.3R/L	0.186	0.098	0.010	0.147
	C3.2 (2a)	0.030	0.012	0.015	0.201
	C3.2 (2b)	0.029	0.012	0.015	0.274
	C3.2 (3b)	0.035	0.012	0.031	0.294
4	C6.2L	0.053	0.074	0.011	0.139
	C-3.4 (2a)	0.024	0.021	0.003	0.187
	C-3.4 (4a)	0.060	0.045	0.011	0.486
	C-3.4 (4b)	-	-	-	0.780
	C8.1L	0.027	0.032	0.010	0.849
	C3.7L ((1a)	0.012	0.009	0.0009	0.022
	C3.7L ((4a)	0.050	0.052	0.005	0.955
	C3.7R/HR	0.047	0.068	0.009	0.124
	C2	0.060	0.088	0.022	0.171
	C1.1-C1.2	0.107	0.012	0.232	
	C 3.8 R (4a)	0.031	0.003	0.898	
5	C 3.8 R (4b)	0.027	0.003	1.848	
	C 3.8 R (5b)	0.027	0.006	1.974	
	C 3.8 R (12a)	0.098	0.011	2.246	
	C3.8R (14)	0.098	0.012	1.239	
	C10.6RL	0.383	0.007	1.074	
	C10.1/2	0.026	0.039	0.130	
5	C10.4,5 & 10.8 (10a)	0.054	0.030	0.120	
	C3.8L (8)	0.124	0.059	0.261	
	C3.8L (17)	0.000	0.062	1.135	
	C3.8L (19a)	0.012	0.068	1.294	

#### 4.3. Evaluation of Existing Drainage Channel Capacity

Evaluation of existing drainage channel capacity is carried out by comparing the discharge capacity in the channel with the run-off discharge is flowing into the

channel. If the discharge capacity is more than the run-off discharge, the channel is said to fulfill and vice versa. Table 5 presents the analysis of existing drainage channel capacity with 5 years return period.

Table 5 Analysis of existing drainage channel capacity with 5 years return period (Own study, 2020)

Zone	Name of channel	Benchmark	Shape of channel	Discharge of channel load (Qsal) (m <sup>3</sup> /s)	Discharge of channel capacity (Qsal) (m <sup>3</sup> /s)	Note	Inundation depth (cm)
1	C – 6.2R	-	Trapezoid	0.256	0.293	Meet	-
2	C6.1	3b	Trapezoid	0.095	0.120	Meet	-
	C7.1-C8.2	2b	Trapezoid	0.213	0.173	Does not meet	0.4
	C7.1-C8.2	3a	Trapezoid	0.289	0.173	Does not meet	1.3
	C7.2	5a	Trapezoid	0.727	0.242	Does not meet	3.8
3	C3.7R/HL	3A	Rectangle	0.051	0.182	Meet	-
	C8.4/HL	3A	Rectangle	0.061	0.297	Meet	-
	C8.1R	7A.R	Trapezoid	0.295	0.252	Does not meet	0.2
		7A.R	Trapezoid	0.353	0.252	Does not meet	0.5
		7A.R	Trapezoid	0.438	0.252	Does not meet	0.9
	C7.1-C8.2	6A L	Trapezoid	0.289	0.234	Does not meet	0.6
		6A R	Trapezoid	0.219	0.234	Meet	-
	C8.3	7B	Trapezoid	0.333	0.325	Does not meet	0.1
	C8.4/HR	3A	Trapezoid	0.078	0.323	Meet	-
		3B	Trapezoid	0.691	0.323	Does not meet	1.8
		8A	Trapezoid	0.804	0.323	Does not meet	2.4
		9B	Trapezoid	1.329	0.323	Does not meet	4.9
4	C4.1	8	Rectangle	0.851	0.899	Meet	-
	Newline	6a	Trapezoid	0.231	1.971	Meet	-
	C3.1	4a	Rectangle	0.143	0.088	Does not meet	0.8
	C.3.3R/L	2a	Rectangle	0.147	0.180	Meet	-
		2a	Rectangle			Meet	-
	C3.2	2a	Circle	0.201	0.530	Meet	-
		2b	Circle	0.274	0.530	Meet	-
		4a	Circle	0.294	0.530	Meet	-
	C6.2L	-	Rectangle	0.139	0.944	Meet	-
	C-3.4	2a	Rectangle	0.187	0.459	Meet	-
		4a	Rectangle	0.486	0.459	Does not meet	0.2
		4b	Rectangle	0.780	0.459	Does not meet	2.8
	C8.1L	4b	Trapezoid	0.424	0.399	Does not meet	0.8
		5a	Trapezoid	0.849	0.399	Does not meet	6.3
	C3.7L	1a	Trapezoid	0.022	0.659	Meet	-
		4a	Trapezoid	0.955	0.659	Does not meet	2.9
	C3.7R/HR	3	Trapezoid rectangle double cross-section	0.124	1.190	Meet	-
C2	3	Trapezoid	0.171	0.773	Meet	-	

Zone	Name of channel	Benchmark	Shape of channel	Discharge of channel load (Qsal) (m <sup>3</sup> /s)	Discharge of channel capacity (Qsal) (m <sup>3</sup> /s)	Note	Inundation depth (cm)
			rectangle double cross-section				
	C1.1-C1.2	7	Circle	0.232	0.108	Does not meet	1.0
	C3.8R	4a	Trapezoid	0.898	1.584	Meet	-
		4b	Trapezoid	1.848	1.584	Does not meet	4.8
		5b	Trapezoid	1.974	1.584	Does not meet	7.0
		12a	Trapezoid	2.246	1.584	Does not meet	10.1
		14a	Trapezoid	1.239	1.584	Meet	-
5	C10.6RL	6R	Trapezoid double cross section	1.074	0.352	Does not meet	3.0
	C10.1/2	11	Trapezoid	0.130	0.367	Meet	-
	C10.4,5 & 10.8	9	Trapezoid double cross section	0.120	0.247	Meet	-
	C3.8L	17A	Rectangle	0.261	1.934	Meet	-
		18A	Rectangle	1.135	1.934	Meet	-
		19A	Rectangle	1.294	1.934	Meet	-

#### 4.4. Evaluation of Collector Channel Based on the Flow Behavior in the Main-drain

Evaluation of flow condition in the channel is carried out by using the analysis of the backwater effect. The increase in the main drain is regulated from the same elevation with the water level in the collector

drain in 5-10 cm until the elevation of water level in the main drain is the same as the highest elevation of channel embankment.

Table 6 presents the recapitulation of inundation depth due to the backwater effect in the channel with 5 years return period.

Table 6 Recapitulation of inundation depth due to the backwater effect in the channel with 5 years return period (Own study, 2020)

Zone	Channel	Area	Volume of inundation	h initial inundation	h inundation	
		m <sup>2</sup>	m <sup>3</sup>	m	M	cm
1	C - 6.2R	8.229.03	729.87	-	0.089	8.869
2	C -7.2	11.429.69	1.960.54	0.038	0.172	17.153
3	C - 8.4 HR	15.347.66	3.122.36	0.049	0.203	20.344
4	C - 3.8R	11.429.69	2.021.30	0.101	0.177	17.685
	C - 10.1.2	12.763.51	370.18	-	0.029	2.900
5	C.10.4,5&8	12.763.51	316.94	-	0.025	2.483
	C.10.6RL	39.166.61	3.057.64	0.030	0.078	7.807

#### 4.5. Application of Under-drain Box Storage Model

The application of the under-drain box storage model follows the cross-section condition of the existing drainage channel. The cross-section shape of the existing drainage channel in the region of Brawijaya University is as follows: trapezoid, rectangle, and semi-circle. The design steps of the under-drain box storage model in the drainage channel are as follow: (analysis sample in the channel zone-1, C-6.2R).

##### 4.5.1. Design of Channel Dimension over Box Storage

##### Data:

Discharge of channel load = 0.256 m<sup>3</sup>/s

Channel length = 312 m

Slope = 0.004

n = 0.015

##### Design result:

Channel shape = semi-circle

Channel width = 0.4 m

H water = 0.322 m (from trial)

Area of channel = 0.19 m<sup>2</sup>

Wet perimeter = 1.04 m

Velocity = 1.33 m/s

Froude number = 0.615

Data:

Froude number = 0.615

4.5.2. Design on the Hole Filling of the Bottom Rack

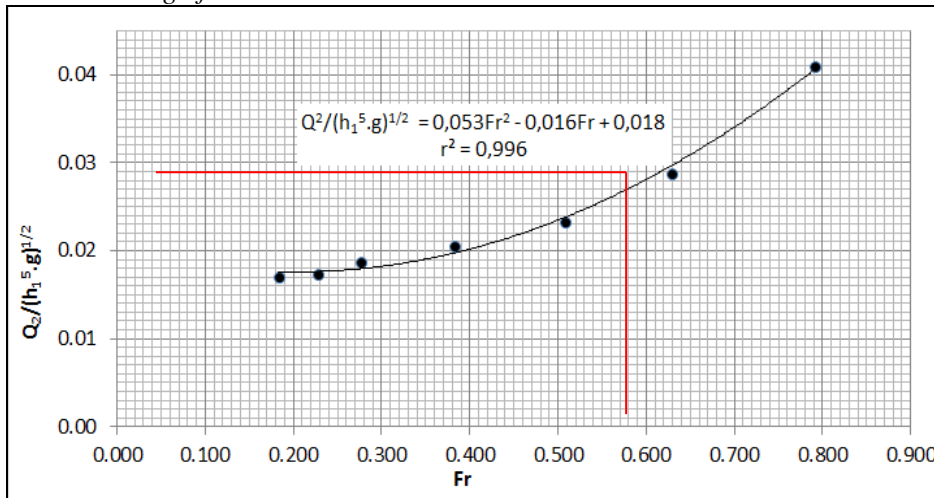

Fig. 1 Curve of non-dimensionless number for circle channel (Own study, 2020)

Based on the curve above, there is obtained the discharge that is through the bottom rack ( $Q_2$ ) is 0.0141  $m^3/s$ .

4.5.3. Design of Box Storage

Data:

Volume of rainfall = 212.38  $m^3$

Volume of channel = 75.77  $m^3$

Volume of drain = Volume of rainfall – Volume of channel = 212.38 – 75.77 = 136.61  $m^3$

Width of storage = 0.4 m

Channel depth = 0.5 m

Lstorage = Lchannel = 312 m

Volume of storage = 62.40  $m^3$

4.5.4. Filling Time of Box Storage

$$T = \frac{V_{storage}}{Q_2} = \frac{62}{0,0141} = 4,435.91 \text{ seconds} =$$

73.93 minutes

For increasing the water enters into the storage, the filling time is designed the same as the travel time of flow that is 12.5 minutes or 750 seconds, so the number of bottom-rack that is needed is as follow:

$$\sum bt = \frac{\text{Volume tampungan}}{T \cdot Q_2} = \frac{62}{750 \times 0,0141} = 5,91 \approx 6$$

bottom racks

So, the number of bottom-rack needed for filling the box storage with the volume of 62  $m^3$  is 6 units of bottom-rack.

4.5.5. Determining the Diameter and Number of Hole

In order to determine the diameter and number of holes in the bottom-rack, the relation curve between discharge and Froude number is presented in Fig. 4.

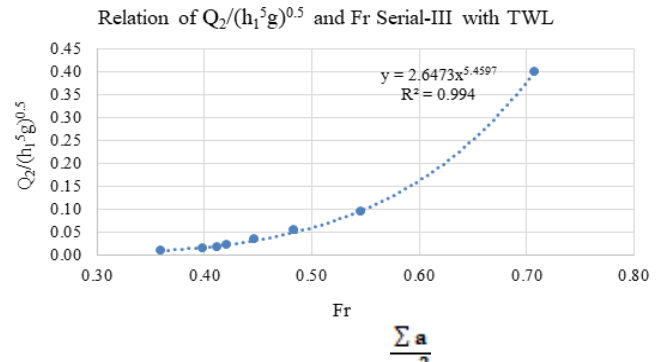

Fig. 2 Relation curve between Fr and  $\frac{\sum a}{h1^2}$  Serial- III with TWL

Based on Fig. 4, with the Froude number of 0.61, there is obtained  $\frac{\sum a}{h1^2} = 0.829$ .

So with the diameter of the design bottom-rack is 1'' = 2.54 cm, the number of bottom-rack is 7 units. The detailed illustrations are presented as in Figs. 5 and 6.

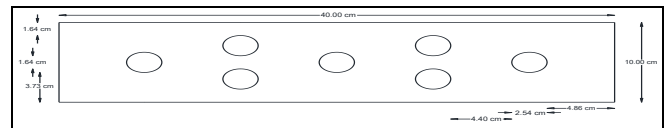

Fig. 3 Placing formation of bottom-rack hole Zone I (Own study, 2020)

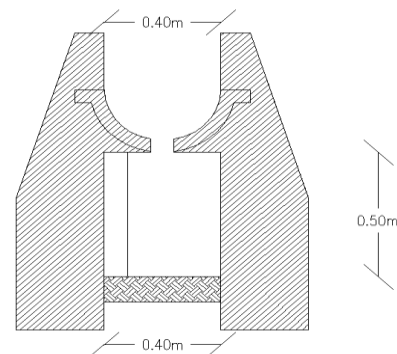

Fig. 4 Detail of UB Drain channel Zone 1 Channel C-6.2 R (Own study, 2020)

#### 4.5.6. Analysis of Absorption Discharge

Type of soil in the region of Brawijaya University is laces which the type of soil has the permeability (k) in amount of  $7.83 \times 10^{-4}$  cm/s [12]. The water volume that is absorbed into soil is as follow [13]:

Data:

Height of box storage = 0.5 m = 50 cm

Absorption area = 1,248,000 cm<sup>2</sup>

Discharge of run-off = 0.256 m<sup>3</sup>/s

Volume of rainfall = 212 m<sup>3</sup>

Volume of box storage = 62.40 m<sup>3</sup>

Discharge of absorption = k x H box storage x Absorption area

=  $7.83 \times 10^{-4} \times 50 \times 1,248,000$

= 488.59 cm<sup>3</sup>/s = 0.0005 m<sup>3</sup>/s

$$\text{Absorption time} = \frac{V \text{ box storage}}{Q_{\text{resap}} \times 3600} =$$

$$\frac{62}{0,000489 \times 3600} = 35 \text{ hours.}$$

The duration of drought or lack of precipitation averages 17 hours (obtained from the ARR recorder in rainfall station of Hydrology Laboratory-Department of Water Resources, Faculty of Engineering-University of Brawijaya-Malang-Indonesia). Therefore, the volume of absorption can be analyzed as follow:

$$V_{\text{absorb}} = V_{\text{box storage}} - ((T_{\text{absorb}} - T_{\text{dry}}) \times 3,600 \times Q_{\text{absorb}})$$

$$= 62 - ((35.48 - 17) \times 3,600 \times 0.000489) = 29.90 \text{ m}^3$$

$$\text{Percentage of absorption water} =$$

$$\frac{V_{\text{resap}}}{V_{\text{hujan}}} \times 100\% = 14.08 \%$$

Table 7 presents the run-off reduction after applying Under-drain Box Storage with 5 years return period.

Table 7 Reduction of the run-off after application of Under-drain Box Storage with 5 years return period (Own study, 2020)

Zone	Channel	Volume of run-off total	Initial condition		Application of Bottom-rack	
			Volume of inundation	Volume of reduction	Volume of inundation	Volume of reduction
		m <sup>3</sup>	m <sup>3</sup>	m <sup>3</sup>	m <sup>3</sup>	m <sup>3</sup>
1	C - 6.2R	212.38	173.36	39.01	44.31	168.07
2	C -7.2	710.45	693.36	17.09	323.18	387.28
	C 6.1	97.71	88.96	8.75	12.34	85.37
	C - 7.1-8.2	157.33	107.21	50.12	26.16	131.17
3	C - 8.4 HR	1,815.14	1,742.89	72.25	585.80	1,229.34
4	C - 3.8R	2,309.86	634.43	1,675.43	668.39	1,641.47
	C - 1.1/1.2	234.26	198.13	36.13	88.86	145.39
	C - 2	57.07	8.08	48.99	0.29	56.77
	C - 3.1	73.72	60.64	13.08	8.71	65.01
	C - 3.2	262.44	232.56	29.89	45.77	216.68
	C - 3.3R/L	44.00	-92.16	136.16	11.36	32.64
	C - 3.4	926.99	891.99	35.00	546.88	380.10
	C - 3.7R HR	280.77	223.49	57.28	166.99	113.78
	C 8.1L	1,005.07	922.92	82.15	559.62	445.45
	5	C - 10.1.2	370.18	245.71	124.47	203.43
C.10.4,5&8		143.60	70.24	73.36	21.34	122.26
C.10.6RL		1,289.32	1,193.84	95.48	576.26	713.06
Total	9,990.29	7,395.65	2,594.64	3,889.69	6,100.60	
Reduction			25.97	%	61.07	%

The application of Under-drain Box Storage in the drainage channel of Brawijaya University can decrease the volume of inundation. However, the volume of run-off will be stored in the box storage and absorbed into the soil and in the drainage channel. Before applying Under-drain Box Storage, the drainage channel in

Brawijaya University could reduce 25.97% of the run-off total; however, the Under-drain Box Storage can reduce 61.07% of the total run-off. Table 8 presents the inundation depth before and after applying Under-drain Box Storage with 5 years return period.

Table 8 The inundation depth before and after application of Under-drain Box Storage with 5 years return period (Own study, 2020)

Zone	Channel	Inundation depth		Allowable head	Note	
		Initial	Bottom-rack		Initial	Bottom-rack
		cm	cm	cm		
1	C - 6.2R	2.58	0.54		Safe	Safe
2	C -7.2	6.22	2.83		Safe	Safe
	C 6.1	3.10	0.39		Safe	Safe
	C - 7.1-8.2	2.60	0.43		Safe	Safe
3	C - 8.4 HR	11.83	3.82		Safe	Safe
4	C - 3.8R	20.21	5.85	15	Not safe	Safe
	C - 1.1/1.2	2.10	0.79		Safe	Safe
	C - 2	0.83	0.00		Safe	Safe
	C - 3.1	2.29	0.27		Safe	Safe
	C - 3.2	2.17	0.38		Safe	Safe
	C - 3.3R/L	1.00	0.26		Safe	Safe

Zone	Channel	Inundation depth		Allowable head cm	Note	
		Initial cm	Bottom-rack cm		Initial	Bottom-rack
5	C - 3.4	8.49	5.01		Safe	Safe
	C - 3.7R HR	3.93	2.34		Safe	Safe
	C 8.1L	8.74	4.87		Safe	Safe
	C - 10.1.2	2.90	1.59		Safe	Safe
	C.10.4,5&8	1.13	0.17		Safe	Safe
	C.10.6RL	3.29	1.47		Safe	Safe
	H Max. inundation	20.21	5.85			

Based on the recapitulation of inundation depth in Brawijaya University with 5 years return period, there is obtained that the inundation depth is 20 cm before the application of Under-drain Box Storage; this inundation is more than the limitation of allowable inundation depth that is 15 cm. However, after applying under-drain box storage, the maximum inundation depth is 5.85 cm, and it is less than the allowable inundation depth.

## 5. Conclusion

In order to solve the inundation problem by applying the existing drainage channel that the model of Under-drain Box Storage modifies is proved very effective to be applied. This model can increase the capacity of the drainage channel in reducing flood as well as it is not difficult in the implementation because there is no need the land acquisition (in the urban area, there is very difficult to carry out the widening of drainage channel). In addition, the very important thing about the model is that the concept is oriented toward natural resources conservation.

Based on the design of the Under-drain Box Storage model, it can be concluded that the drainage channel in Brawijaya University can reduce flood by the control of inundation depth is not more than the allowable inundation depth that is 15 cm. However, the reduced ability of the channel with 2 years return period can reduce 73.73%, with 5 years return period can reduce 61.07%, and with 10 years return period can reduce 58.07%.

For the implementation in the field, the construction of Under-drain Box Storage is suggested as follow:

1. For selecting the diameter of the bottom-rack hole, it is suggested to use the dimension that is easy to obtain in the marketplace, making it easy to implement.
2. In order to carry out, the periodical maintenance can be easily done, and it is suggested to use plug and paly concrete or steel bottom-rack on the construction of Under-drain Box Storage.
3. The use of bottom-rack is suggested using the maximum thickness of the plate is 0.5 cm.

## References

- [1] CHEN J., LIAO A., CHEN J. 30-meter global land cover data product - GlobeLand30. *Journal of Geomatics World*, 2017 (In Chinese).
- [2] CHEN J., DOWMAN I., and LI S. Information from imagery: ISPRS scientific vision and research agenda.

*Journal of Photogrammetry & Remote Sensing*, 2016, 115, p.3-21

- [3] ROMANOWICZ R. and BEVEN K. Dynamic real-time prediction of flood inundation probabilities. *Hydrological Sciences Journal*, 1998, 43:2, p. 181-196
- [4] ANDERSON M. G. and BATES P. D. Initial testing of a two dimensional finite element model for floodplain inundation. *Proceedings of the Royal Society, Series A*, 1994, 444: 149-159.
- [5] BATES P. D., BAIRD L., ANDERSON M. G., WALLING D. E., and SIMM D. Modelling floodplain using a 2-dimensional finite element model. *Earth Surface Processes and Landforms*. 1992, 17: 577-588.
- [6] BEVEN K. J. and BINLEY A. The future of distributed models: model calibration and uncertainty prediction. *Hydrological Processes*, 1992, 6: 279-298.
- [7] PRIYANTORO D. and LIMANTARA LM Conformity evaluation of synthetic unit hydrograph (case study at upstream Brantas subwatershed, East Java Province of Indonesia). *Journal of Water and Land Development*, 2017, 35: 173-183. DOI: 10.1515/jwld-2017-0082.
- [8] JUWONO PT, LIMANTARA LM, and AMRIE S. The effect of land-use change to the area of inundation in the Bang sub-watershed-Malang-Indonesia. *International Journal of Geomate*, 2019, 16 (53): 238-244.
- [9] KUNCORO Y. *Uji model fisik kapasitas aliran pada lubang pengisian tampungan di bawah saluran drainasi (Physical model test of flow capacity in the under-drain box storage)*. Program Magister Dan Doktor Teknik Pengairan, Fakultas Teknik, Universitas Brawijaya, 2012.
- [10] HARTO S. *Analisis hidrologi (Hydrology analysis)*. Gramedia Pustaka Utama, Jakarta, 1993.
- [11] ASDAK C. *Hidrologi dan pengolahan daerah aliran sungai (Hydrology and watershed management)*. Gadjah Mada University Press, Yogyakarta, 1995.
- [12] SURYO E. *Upaya penanggulangan genangan dan peningkatan resapan air menggunakan Under-drain Box Storage di kawasan kampus Universitas Brawijaya*. Teknik Pengairan, Fakultas Teknik, Universitas Brawijaya, 2013.
- [13] SUNJOTO A.S. *Analisa sumur resapan serta pengembangannya (Analysis of absorption well and the development)*. Sarasehan Ilmiah, Departemen Pekerjaan Umum, 1998.

## 参考文献:

- [1] CHEN J., LIAO A., CHEN J. 30米全球土地覆盖数据产品-环球土地三十. *地球物理学报*, 2017.
- [2] CHEN J., DOWMAN I. 和 LI S. 图像信息: ISPRS 科学愿景和研究议程. *摄影测量与遥感杂志*, 2016 年, 115, 第 3-21 页
- [3] ROMANOWICZ R. 和 BEVEN K. 洪水淹没概率的动态实时预测. *水文科学杂志*, 1998 年, 43: 2, p. 181-

- 196
- [4] ANDERSON M. G. 和 BATES P. D. 洪氾區淹沒二維有限元模型的初步測試。英國皇家學會會刊，一種系列，1994 年，444: 149-159。
- [5] BATES P. D.、BAIRD L.、ANDERSON M. G.、WALLING D. E. 和 SIMM D. 使用二維有限元模型模擬洪氾區。地球表面過程和地貌。1992, 17: 577-588。
- [6] BEVEN K. J. 和 BINLEY A. 分佈式模型的未來：模型校準和不確定性預測。水文過程，1992, 6: 279-298。
- [7] PRIYANTORO D. 和 LIMANTARA L.M. 合成單位水文線的一致性評估（印度尼西亞東爪哇省布蘭塔斯分流域上游的案例研究）。水土發展雜誌，2017, 35: 173-183。DOI: 10.1515/jwld-2017-0082。
- [8] JUWONO P.T.、LIMANTARA L.M. 和 AMRIE S. 土地利用變化對砵子流域-瑪瑯-印度尼西亞淹沒區的影響。國際地質學雜誌, 2019, 16 (53): 238-244。
- [9] KUNCORO Y. 地下排水箱庫中流通能力的物理模型試驗。布拉維賈亞大學工程學院水工程碩士和博士課程，2012 年。
- [10] HARTO S. 水文分析（水文分析）。主圖書館語法雅加達，1993 年。
- [11] ASDAK C. 水文和流域管理。加札馬達大學出版社，日惹，1995 年。
- [12] SURYO E. 在布拉維賈亞大學校園區使用地下排水箱存儲來克服洪水和增加吸水率的努力。水工程，工程學院，布拉維賈亞大學，2013 年。
- [13] SUNJOTO A.S. 吸收井及其開發分析（分析吸收井與開發）。公共工程部科學研討會，1998 年。